



Vehicle History Report

VEHICLE DETAILS

Chassis number ¹: WDB1400501A125319

Manufacture date: 1993-02-05

Make: MERCEDES BENZ

Model: S CLASS

Body:

Grade: 500SE 6.0 AMG

Engine: 119970

Drive: 2WD

Transmission: AT

Title information ²:



Deregistered to Export



Accident / Repair:



No problem



Odometer rollback:



No problem



Manufacturer recall:



No problem



Safety grade ³:



No data



Contamination risk:



No problem



This CAR VX Vehicle History Report is based only on Information supplied to CAR VX, LTD and available as of 2026-06-24 15:28:01. Other information about this vehicle, including problems, may not have been reported to CAR VX, LTD . Use this report as one important tool, along with a vehicle inspection and test drive, to make a better decision about your next used car.

ACCIDENT / REPAIR HISTORY

| Problem type | Reported | Date reported | Data source | Details | Airbag |
|--------------|--------------|---------------|-------------|---------|--------|
| Collision | Not reported | | | | |
| Malfunction | Not reported | | | | |
| Theft | Not reported | | | | |
| Fire damage | Not reported | | | | |
| Water damage | Not reported | | | | |
| Hail damage | Not reported | | | | |

ODOMETER READINGS HISTORY

| Date reported | Data source | Odometer reading (Km) |
|---------------|-------------|-----------------------|
| 2010-07-15 | MLIT | 108800 |
| 2012-07-20 | MLIT | 124600 |
| 2013-04-18 | USS Tokyo | 130796 |

USE HISTORY

| | | |
|---|---|-----------------------|
| Use in the contaminated regions ⁴ | Radioactive contamination test fail ⁵ | Commercial use |
| Not reported | Not reported | Not reported |

DETAILED HISTORY

| Event date | Location | Odometer reading (Km) | Data source | Details |
|------------|-----------|-----------------------|---------------|--------------------|
| 1993-02-05 | | | MERCEDES BENZ | Manufactured |
| 1993-07 | | | MLIT | First registration |
| 2010-07-15 | | 108800 | MLIT | Inspection |
| 2012-07-20 | Shinagawa | 124600 | MLIT | Inspection |
| 2013-04-18 | Chiba | 130796 | USS Tokyo | Auctioned |

MANUFACTURER RECALL HISTORY

| Date reported | Data source | Affected part | Details |
|---|-------------|---------------|---------|
|  Not reported | | | |

VEHICLE ASSESSMENT ⁶

Overall Collision Safety Ratings

| Driver's seat | | | Front passenger's seat | | |
|---------------|------------|--------------|------------------------|------------|--------------|
| Points | Evaluation | Goal average | Points | Evaluation | Goal average |
| 0 | | 0% | 0 | | 0% |

* In order to accurately differentiate between the evaluations of different vehicles, a standard is set based on current technology. Up to 6 points out of 12 is given level 1 and the rest of the range is divided up into equal parts, which are respectively assigned to level 2 (more than 6 points but 7.5 or less), level 3 (more than 7.5 points but 9 or less), level 4 (more than 9 points but 10.5 or less) or level 5 (more than 10.5 points).

Braking performance tests ⁷

Dry road



Wet road



VEHICLE SPECIFICATION

1st gear ratio

2nd gear ratio

3rd gear ratio

4th gear ratio

5th gear ratio

6th gear ratio

Additional notes

Airbag position, capacity

Body rear overhang

Body type

SEDAN

Chassis number embossing position

Classification code

| | | | |
|---------------------------------------|--------------------|---------------------------------------|--------------------|
| Cylinders | 8 | Displacement | 5950 |
| Electric engine type | | Electric engine maximum output | |
| Electric engine maximum torque | | Electric engine power | |
| Engine maximum power | 381 PS @ 5,500 rpm | Engine maximum torque | 580 Nm @ 3,800 rpm |
| Engine model | 119970 | Frame type | |
| Front shaft weight | 1110 | Front shock absorber type | |
| Front stabilizer type | | Front tires size | 245/45ZR18 |
| Front tread | 1600 | Fuel consumption | |
| Fuel tank equipment | 100 | Grade | 500SE 6.0 AMG |
| Height | 147 | Length | 512 |
| Main brakes type | | Make | MERCEDES BENZ |
| Maximum speed | | Minimum ground clearance | |
| Minimum turning radius | 6.3m | Model | S CLASS |
| Model code | | Mufflers number | |
| Rear shaft weight | 1000 | Rear shock absorber type | |
| Rear stabilizer type | | Rear tires size | 265/40ZR18 |
| Rear tread | 1600 | Reverse ratio | |
| Riding capacity | 5 | Side brakes type | |
| Specification code | | Stopping distance | |
| Transmission type | AT | Weight | 2130 |
| Wheel alignment | 2WD | Wheelbase | 3040 |
| Width | 191 | | |

AUCTION DATA

Date: 2013-04-18, Auction: USS Tokyo, Lot #: 70139

Date: 2013-04-18 Lot #: 70139

Auction name: [USS Tokyo](#) Region: Chiba

| | | | |
|--------------------|---------------|----------------|---------|
| Make: | MERCEDES BENZ | Model: | S CLASS |
| Reg. year: | 1993 | Mileage (km): | 130796 |
| Displacement (cc): | 6000 | Transmission: | FA |
| Color: | SILVER | Model code: | DL |
| Result: | unsold | Auction grade: | R |
| Problem type: | No problem | Problem scale: | None |
| Contaminated: | No | Airbag: | OK |

PHOTOS AND AUCTION SHEETS

輸入車①コーナー

| | | | | |
|---------------------------|-----------------------------|---------------------------------------|----------------------------|----------|
| 70139 | 車歴 自家用 | 排気量 6.000 cc | 型式 7×1 | 評価点 R |
| 初度登録年月 5/7月 | 車名 ベンツS724SD500SE-6.0AMG | 駆動方式 4WD | グレード 4WD | 内装 B |
| 車検 26年 8月 | シフト FAT | 装備品 SR, AV, PS, PW, カワ, TV, ナビ, アビ | 冷房 AAC | セールスポイント |
| 走行 130,796 Km | 新車整備手帳 (保証書付) 有・無 | ※純正品に限り該当に○をつけて下さい。 | | |
| 外色 シルバー | 燃料 ガソリン・軽油・() | 名義変更期間 | | |
| 内装色 ブラック | 輸入区分 デューラー並行 | 月 日 | | |
| リサイクル預託金 19,110円 預託済み | 乗車定員 5人 | 登録No. 新潟 30i さ 6954 | 車台No. WDBJ400501A125319 | |
| ※リサイクル預託金に廃棄物処理料金は含まれません。 | | | | |

※ご記入の際は油性ボールペンで強くご記入下さい。(水性ペンは使わないで下さい)

《買取車》(初出品)★ワレオーナー★
取説、ディーラーワ、スピーカー、ナビレコン
バックオーディオレコン

●検査員報告

12Vバッテリー F1修理
下廻りサセ
右Pインパ Fエンジンカバー
巧サポート オイルニジ
Fガラスは XX
A1キス 谷村口、木山

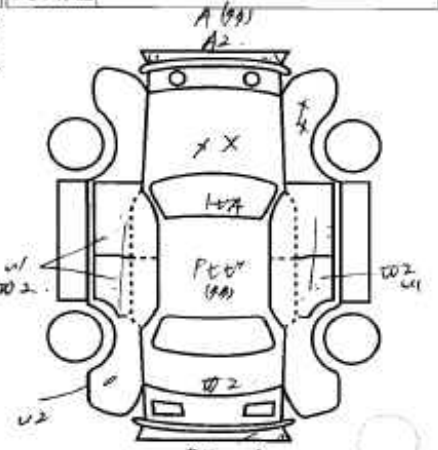

長さ cm 幅 cm 高さ cm (車検証上の寸法) スペア





1 Chassis number – a unique identification number of the vehicle in Japan (same as VIN in the USA or Europe)

2 Title information:

Registered – qualified for driving in Japan

Deregistered Temporarily – not qualified for driving in Japan, usually a temporary title during the ownership change

Deregistered Completely – not qualified for driving in Japan, the vehicle is determined to be scrapped

Deregistered to Export – not qualified for driving in Japan, the vehicle is determined to be exported

3 Determining the overall collision safety performance evaluation – For the driver's seat, the results of the full-wrap frontal collision test, offset frontal collision test, and side collision test are added together and evaluated to 6 different levels. For the Frontal passenger's seat, the results of the full-wrap frontal collision test and the side collision test (results for the driver's or the front passenger's seat are used) are added together and evaluated to 6 different levels.

Regular vehicle inspection – All vehicles in Japan must undergo regular vehicle inspections (shaken). New cars need to be tested after three years, and then vehicles must be tested every two years thereafter. A vehicle inspection (shaken) is compulsory for all vehicles with an engine size over 250cc. It ensures that all vehicles on the road are properly maintained and safe to drive. The test also checks that vehicles have not been illegally modified; if they are found to have been modified, they are not allowed on the road.

4 Use in the contaminated regions – The Fukushima Daiichi nuclear disaster was a catastrophic failure at the Fukushima I Nuclear Power Plant on 11 March 2011, resulting in a meltdown of three of the plant's six nuclear reactors. As a result, some areas in the following prefectures were contaminated: Fukushima, Miyagi, Ibaraki, Tochigi.

5 Radioactive contamination test – radioactive contamination inspection that was started in July 2011 as a preventive measure for exporting contaminated vehicles from Japan. The inspection is being conducted since in all sea ports of Japan under the supervision of The Japan Harbor Transportation Association (JHTA).

MLIT – Ministry of Land, Infrastructure, Transport and Tourism.

6 Japan New Car Assessment Program – the Ministry of Land, Infrastructure, Transport and Tourism (MLIT) and the National Agency for Automotive Safety & Victims' Aid (NASVA) have taken measures for safety, one of which is to assess commercially available vehicles through a variety of safety performance tests and release the resulting information compiled into the "New Car Assessment Program". The objective of Japan New Car Assessment Program is to increase the use of safe automobiles by providing an environment in which users can easily select such vehicles. This also promotes the development of safer vehicles by automobile manufacturers. Neck injury protection for rear-end collision performance test, rear seat passenger's protection for frontal collision performance test, rear passenger's seat belt usability evaluation test and seat belt reminder for passengers evaluation test are started in FY2009.

7 Braking Performance Tests – Braking performance is determined by the shortness of the distance in which a vehicle can stop and the stability of the vehicle at the time of braking. This test is performed under wet and dry road conditions for a vehicle which has both a driver and a front passenger. The distance it takes for the vehicle to stop and the stability of the vehicle at the time of braking is evaluated for when the vehicle is stopped abruptly while traveling at a speed of 100km/h. The stopping distance and vehicle speed have been measured by using GPS since FY2009.

THEREFORE, NO RESPONSIBILITY IS ASSUMED BY CAR VX, LTD OR ITS AGENTS FOR ERRORS OR OMISSIONS IN THIS REPORT. CAR VX, LTD FURTHER EXPRESSLY DISCLAIMS ALL WARRANTIES, EXPRESSED OR IMPLIED, INCLUDING ANY IMPLIED WARRANTIES OF MERCHANTABILITY OR FITNESS FOR A PARTICULAR PURPOSE.

© 2014-2026 Car VX Limited. All rights reserved.